

Rod Ends Series K - Standard

Series GA

Rod Ends with male thread made from free-cutting or heat-treated steel, zinc plated and fitted with a grease nipple

Especially suited for axial loads

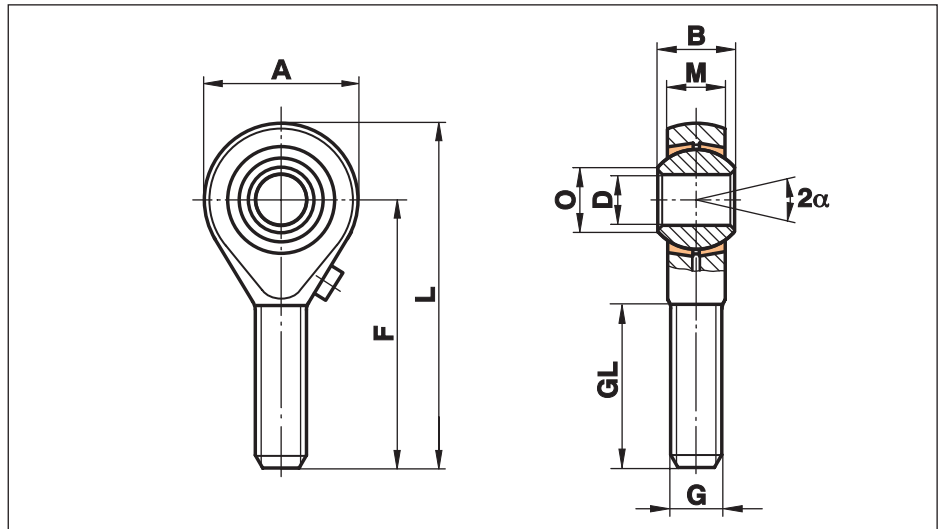

Size (D)	B	M	A	F	L	O	G	GL	Static load C ₀ kN	Dynamic load C kN	Limiting speed rev/min	Weight g
5 ¹⁾	8	6,00	18	33	42	7,7	M 5	20	4,3	2,5	900	13
6	9	6,75	20	36	46	8,9	M 6	22	6,0	3,2	760	20
8	12	9,00	24	42	54	10,4	M 8	25	11,0	5,4	620	33
10	14	10,50	28	48	62	12,9	M 10	29	17,4	7,5	500	56
12	16	12,00	32	54	70	15,4	M 12	33	25,5	10,0	450	87
14	19	13,50	36	60	78	16,8	M 14	36	24,5	13,0	360	129
16	21	15,00	42	66	87	19,3	M 16	40	36,5	16,0	350	189
18	23	16,50	46	72	95	21,8	M 18x1,5	44	43,0	19,5	320	267
20	25	18,00	50	78	103	24,3	M 20x1,5	47	49,5	23,5	280	348
22	28	20,00	54	84	111	25,8	M 22x1,5	51	57,0	29,0	250	443
25	31	22,00	60	94	124	29,6	M 24x2	57	68,0	35,0	230	600

Materials:

Housing: up to size 12 turned from free-cutting steel to 9SMnPb28K, 12L13
from size 14 forged from heat-treated steel to C22, M1023

Insert: Special brass to CuZn38Al1

Ball: Bearing steel to 100Cr6, Aisi 52100, hardened, ground, polished

¹⁾ without lubrication hole